

Surface contact temperature sensors /
tube contact temperature sensors, including strap,
with passive output

THERMASGARD® ALTF 2 is a tube contact resistance thermometer with passive output, in an impact-resistant plastic housing with quick-locking screws, incl.strap.

THERMASGARD® ALTF 02 is a cost-saving tube contact resistance thermometer with passive output, in an impact-resistant plastic housing with snap-on lid, incl.strap.

Surface contact sensors are electric contact thermometers used for surface temperature measurement on solids, having at least one so-called contact area that is brought into contact with the surface to be measured. This surface contact temperature sensor measures the temperature of a medium flowing inside a pipe (e.g. the water temperature). This tube surface sensor is used for measuring temperature on piping and tubes (e.g. cold-water and hot-water), wor on heating sections for heating system control.

TECHNICAL DATA

Measuring range:	-30...+110 °C
Sensors / output:	see table, passive (Perfect Sensor Protection) (optional also with two sensors)
Connection type:	2-wire connection (4-wire connection on PT100/PT1000A, optional on other sensors)
Testing current:	< 0.6 mA (Pt1000) < 1.0 mA (Pt100) < 0.3 mA (Ni1000, Ni1000 TK5000) < 2.0 mW (NTC xx) 400 µA...5 mA (LM235Z)
Housing:	plastic, UV-resistant, material polyamide, 30 % glass-globe reinforced, colour traffic white (similar to RAL 9016), ALTF 02 with snap-on lid, ALTF 2 with quick-locking screws (slotted / Phillips head combination)
Dimensions:	72 x 64 x 37.8 mm (Tyr 1 / Tyr 01)
Electrical connection:	0.14 - 1.5 mm ² via terminal screws
Cable connection:	cable gland , plastic (M 16 x 1.5; with strain relief, exchangeable, max. inner diameter 10.4 mm) or M12 connector according to DIN EN 61076-2-101 (optional on request)
Process connection:	with endless strap with metal tightener (included in the scope of delivery) Ø = 13 - 92 mm (1/4 - 3"), length L = 300 mm
Insulating resistance:	≥ 100 MΩ, at +20 °C (500 V DC)
Humidity:	< 95 % RH, non-precipitating air
Protection class:	III (according to EN 60 730)
Protection type:	ALTF 02 IP 54 (according to EN 60 529) Housing tested, TÜV SÜD, Report No. 713160960A (Tyr 01) ALTF 2 IP 65 (according to EN 60 529) Housing tested, TÜV SÜD, Report No. 713139052 (Tyr 1)

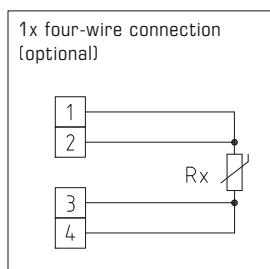
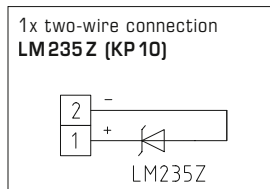
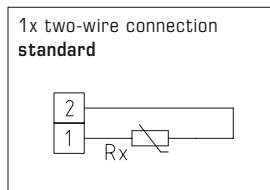

THERMASGARD® ALTF 02 Surface contact temperature sensors / tube contact temperature sensors, *Standard*
including strap, with snap-on lid

Type / WG03B	Sensor / Output	Item No.	Price
ALTF 02		IP 54	
ALTF02 Pt100	Pt100 (according to DIN EN 60 751, class B)	1101-1010-1003-000	23,89 €
ALTF02 Pt1000	Pt1000 (according to DIN EN 60 751, class B)	1101-1010-5001-000	23,89 €
ALTF02 Ni1000	Ni1000 (according to DIN EN 43 760, class B, TCR = 6180 ppm / K)	1101-1010-9001-000	24,30 €
ALTF02 NiTK	Ni1000 TK5000 (TCR = 5000 ppm / K), LG - Ni1000	1101-1011-0001-000	27,82 €
ALTF02 LM235Z	LM235Z (TCR = 10 mV / K; 2.73 V at 0 °C), KP10	1101-1012-1001-000	24,59 €
ALTF02 NTC1,8K	NTC 1.8K	1101-1011-2001-000	23,18 €
ALTF02 NTC10K	NTC 10K	1101-1011-5001-000	23,18 €
ALTF02 NTC20K	NTC 20K	1101-1011-6001-000	23,18 €
Extra charge:	two or other sensors optional cable connection with M12 connector according to DIN EN 61076-2-101	on request on request	

ACCESSORIES

WLP-1	Heat-conductive paste, silicone-free	7100-0060-1000-000	5,13 €
--------------	--------------------------------------	--------------------	---------------



S+S REGELTECHNIK

THERMASGARD® ALTF 2
THERMASGARD® ALTF 02

Surface contact temperature sensors /
tube contact temperature sensors, including strap,
with passive output



Dimensional drawing

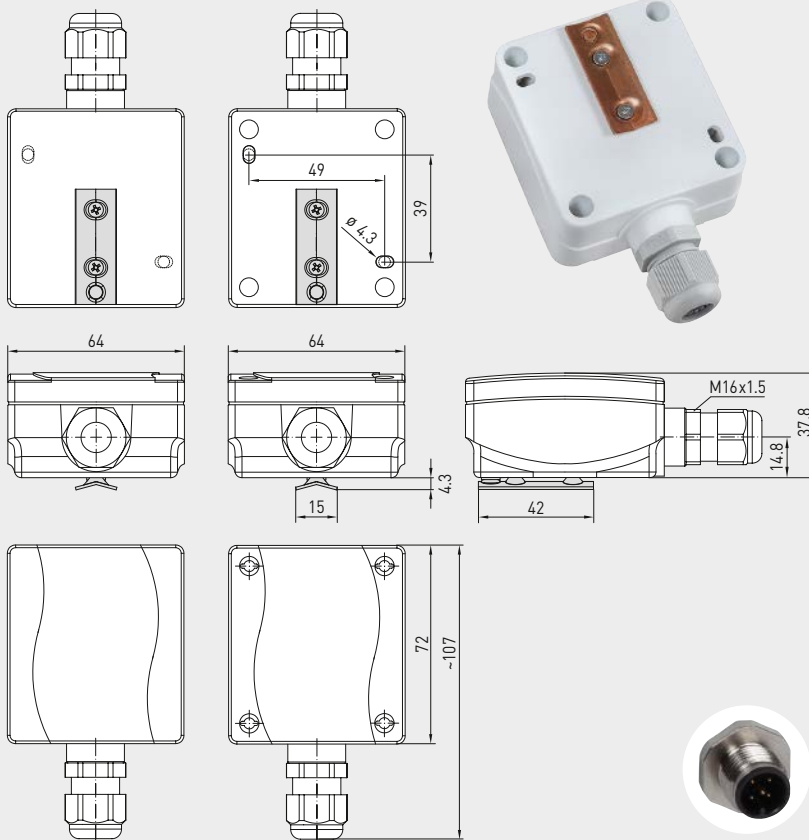

ALTF 2
ALTF 02

with snap-on lid

with quick-locking
screws

M12 connector
(optional on request)

ALTF 02
with snap-on lid
(IP54)



ALTF 2
with quick-locking
screws
(IP65)



High-performance encapsulation against
vibration, mechanical stress and humidity



THERMASGARD® ALTF 2 Surface contact temperature sensors / tube contact temperature sensors, *Premium*
including strap, with quick-locking screws

Type / WG03	Sensor / Output	Item No.	Price
ALTF 2		IP 65	
ALTF2 Pt100	Pt100 (according to DIN EN 60 751, class B)	1101-1020-1003-000	27,74 €
ALTF2 Pt1000	Pt1000 (according to DIN EN 60 751, class B)	1101-1020-5001-000	28,53 €
ALTF2 Pt1000A	Pt1000 (according to VDI/VDE 3512, class A-TGA)	1101-1020-6003-000	32,43 €
ALTF2 Ni1000	Ni1000 (according to DIN EN 43 760, class B, TCR = 6180 ppm / K)	1101-1020-9001-000	28,12 €
ALTF2 NiTK	Ni1000 TK5000 (TCR = 5000 ppm / K), LG-Ni1000	1101-1021-0001-000	32,97 €
ALTF2 LM235Z	LM235Z (TCR = 10 mV / K; 2.73 V at 0 °C), KP10	1101-1022-1001-000	27,21 €
ALTF2 NTC1,8K	NTC 1.8K	1101-1021-2001-000	23,66 €
ALTF2 NTC10K	NTC 10K	1101-1021-5001-000	23,66 €
ALTF2 NTC20K	NTC 20K	1101-1021-6001-000	23,66 €
Extra charge:	two or other sensors optional cable connection with M12 connector according to DIN EN 61076-2-101	on request on request	

ACCESSORIES

WLP-1	Heat-conductive paste, silicone-free	7100-0060-1000-000	5,13 €
--------------	--------------------------------------	--------------------	---------------