

**Fine dust sensor / particulate sensor,  
on-wall sensor and measuring transducer, with multi-range switching  
and active output**

Maintenance-free on-wall sensor **AERASGARD® APS-SD** with active output, in an impact-resistant plastic housing with quick-locking screws, for measuring the fine-dust content (0...500 µg/m³). The measuring transducer converts the measured values into a standard signal of 0-10V.

The sensor is used in offices, hotels, convention centres, apartments, shops, etc. and is used for evaluation of the indoor climate. This enables energy-saving, demand-based room ventilation, thereby reducing operating costs and improving well-being. One sensor for every 30m² of room area is recommended.

An optical **fine dust sensor** precisely detects **particulate (PM)** of the size category 0.3 to 10 micrometres. The sensor is factory-calibrated.

**TECHNICAL DATA**

Power supply:	24 V AC / DC (± 10%)
Power consumption:	typical < 1.5 W / 24 V DC; < 2.9 VA / 24 V AC
Output:	0-10 V
<b>FINE DUST (PM)</b>	
Sensor (PM):	optical <b>particulate sensor (PM = particulate matter), fine-dust sensor with laser- and soiling-resistant technology</b>
Measuring range:	multi-range switching (selectable via DIP switches) 0...50, 0...100, 0...300 or 0...500 µg/m³
Particle size:	<b>PM 2.5</b> (0.3...2.5 µm); <b>PM 10</b> (0.3...10 µm)
Accuracy:	typical ± 10 µg/m³ (± 10% of the measured value) for PM 2.5 typical ± 25 µg/m³ (± 25% of the measured value) for PM 10
Long-term stability:	± 1.25 µg/m³ (± 1.25% of measured value/year)
Service life:	> 10 years
Response time:	< 2 minutes
Warm-up time:	approx. 1 hour
Ambient temperature:	0...+50 °C
Permitted humidity:	0...95% RH (non-precipitating air)
Housing:	plastic, UV-resistant, polyamide material, 30% glass-globe reinforced, with quick-locking screws (slotted/Phillips head combination) colour traffic white (similar to RAL 9016)
Housing dimensions:	126 x 90 x 50 mm (Tyr 2)
Cable connection:	<b>cable gland</b> plastic (M 16 x 1.5; with strain relief, exchangeable, max. inner diameter 10.4 mm) <b>or</b> <b>M12 connector</b> according to DIN EN 61076-2-101 (optional on request)
Electrical connection:	0.14–1.5 mm², via screw terminals
Process connection:	via screws
Protection class:	III (according to EN 60 730)
Safety class:	<b>IP 30</b> (according to EN 60 529)
Standards:	CE-conformity according to EMC Directive 2014 / 30 / EU

DIP switch	APS-SD	
<b>Fine dust (PM) Measuring range</b>	<b>DIP 1</b>	<b>DIP 2</b>
0...50 µg/m³	OFF	OFF
0...100 µg/m³ (default)	<b>ON</b>	OFF
0...300 µg/m³	OFF	<b>ON</b>
0...500 µg/m³	<b>ON</b>	<b>ON</b>
<b>Fine dust (PM) Particle size</b>	<b>DIP 3</b>	
PM 2.5 (default)	<b>ON</b>	
PM 10	OFF	
Note: <b>DIP 4</b> is not assigned !		

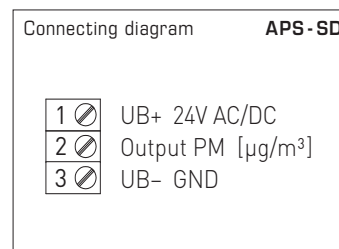
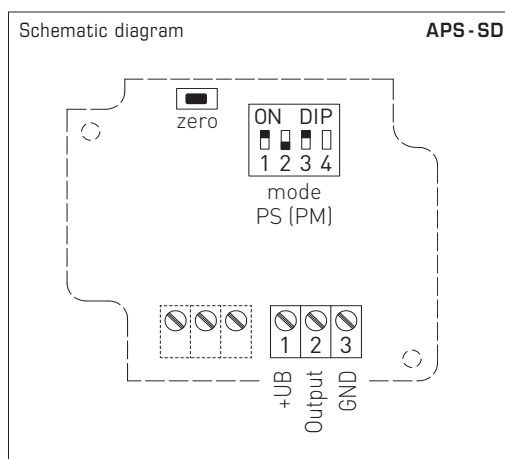



S+S REGELTECHNIK

AERASGARD® APS-SD

Fine dust sensor / particulate sensor,  
on-wall sensor and measuring transducer, with multi-range switching  
and active output



Dimensional drawing

APS-SD

APS-SD

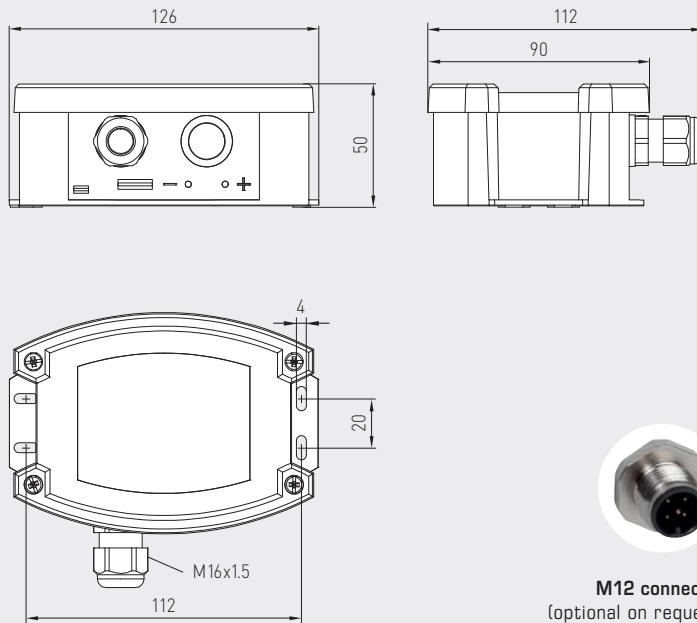

M12 connector  
(optional on request)



AERASGARD®  
APS-SD

On-wall fine dust sensor / fine dust sensor / particulate sensor (PM), Standard

Type / WG02	Measuring Range	Particle size	Output	Item No.
<b>APS-SD</b>	(switchable)	(switchable)		
APS-SD-U	0... 50 µg/m <sup>3</sup> 0... 100 µg/m <sup>3</sup> 0... 300 µg/m <sup>3</sup> 0... 500 µg/m <sup>3</sup>	PM 2.5 PM 10	0-10V	1501-7130-1001-000

Optional: Cable connection with **M12 connector** according to DIN EN 61076-2-101 (on request)

**Note:** This unit **must not** be used as safety-relevant device!