

In-ceiling motion detector, light, humidity and temperature sensor, multisensors with switching output

The in-ceiling sensor **KINASGARD® DBWF/LF/FTF** is used to detect persons within a distance of up to 10 meters and to measure luminous intensity or brightness, relative humidity and temperature. It has been designed for installation in suspended ceilings.

The sensor detects **motion** over an aperture angle of 110° and a perimeter of 360°. The patented lens system with 20 individual lenses results in only very small dark areas that are only a few centimetres wide even at a distance of 10 m, thereby reliably detecting small movements. If motion is detected, the potential-free relay output is switched. The hold time of the output, measured from the moment of the last detected movement, can be preset internally in the device via potentiometer within a range of 4 seconds to approx. 17 minutes.

For the **temperature and humidity**, an analogue output 0 - 10 V corresponding to 0...+50 °C or 0...100 % RH is available. Deviations due to the mounting position and location can be compensated internally using one offset regulator respectively.

For **luminous intensity or brightness** of 0...1000 lux or 0...5000 lux (selectable via DIP switches), an analogue output 0 - 10 V is also available. It is also possible to activate the motion output depending on brightness with the help of a jumper.

Fields of application for the DBWF/LF/FTF include residential room monitoring, automatic switching of lights, control technology, alarm technology, and motion-dependent control of room functions, e. g. for lowering the temperature in unused rooms.

TECHNICAL DATA

Power supply:	24 V AC/DC (half-wave rectification, read the instructions!)
Power consumption:	< 3.6 VA at 24 V DC
Electrical connection:	0.14 - 1.5 mm ² , via terminal screws
Outputs:	0-10 V or inverted 10-0 V (selectable via DIP switches)

MOTION	
Sensor:	infra-red motion sensor
Detection range:	perimeter 360°, aperture angle 90° / 110°, reach approx. 10 m, circular, at an installation height of approx. 3 m the sensor covers a detection radius (r) of approx. 3.4 m
Motion detection:	of persons and objects, necessary temperature difference between subject and surroundings ≥ 5 K
Output, motion sensor:	potential-free changeover contact, for switching safety extra-low voltage only, up to 1 A
After-running time:	adjustable from 4 s to 17 min

LIGHT INTENSITY	
Sensor:	light sensor with diffusor
Measuring range, light sensor:	0...1000 lux / 0...5000 lux (selectable via DIP switches)
Output, light sensor:	0 - 10 V
Accuracy, light sensor:	typically < ± 10% of final value (referred to calibration reference source, approx. 5700 K)
Temperature drift:	< ± 5 % of final value / 10 K at +20 °C

HUMIDITY	
Measuring range, humidity:	0...100 % RH (output corresponding to 0 - 10 V)
Operating range, humidity:	10...95 % RH (non-precipitating air)
Accuracy, humidity:	typically ± 3 % RH (20...80 %); at +20 °C, otherwise ± 5 % RH
Output, humidity:	0-10 V

TEMPERATURE	
Measuring range, temperature:	0...+50 °C (output corresponding to 0 - 10 V) other measuring ranges on request!
Operating range, temperature:	0...+50 °C
Accuracy, temperature:	typically ± 0.8 K at +20 °C, under standard conditions
Output, temperature:	0-10 V
Ambient temperature:	0...+50 °C
Storage temperature:	-20...+50 °C
Housing:	steel, white painted
Housing dimensions:	cover: Ø 96 mm, height of housing: 30 mm
Installation dimensions:	ceiling cutout: Ø 80 mm installation depth: < 45 mm (incl. connector system) on-wall protrusion: > 13 mm (motion sensor) > 20 mm (humidity sensor)

Sensor protection:	mounted inside ceiling installation housing
Protection class:	III (according to EN 60 730)
Protection type (housing):	IP 20 (according to EN 60 529)
Standards:	CE conformity according to EMC directive 2014/30/EU

Function output (direction adjustable)	DIP 1
normal (default) 0 % = 0 V 100 % = 10 V	OFF
inverted 0 % = 10 V 100 % = 0 V	ON

Brightness (adjustable measuring range)	DIP 3
0... 1000 Lux (default)	OFF
0... 5000 Lux	ON

Motion (mode selectable)	DIP 4
Motion mode (default) Motion detector is independent of threshold value	OFF
Auto mode If the set threshold value is not reached, the motion detector is active	ON

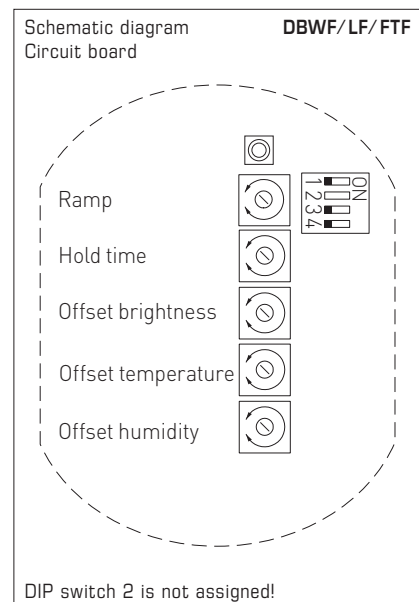



S+S REGELTECHNIK

In-ceiling motion detector, light, humidity and temperature sensor, multisensors with switching output

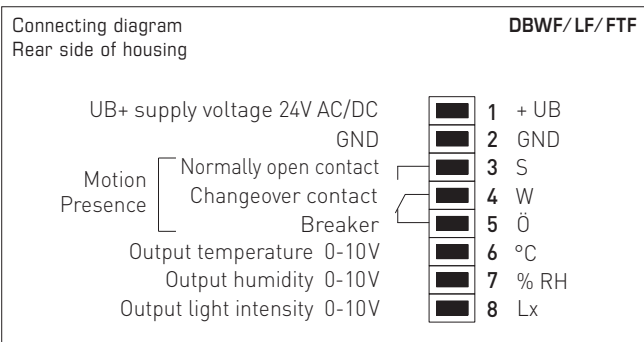
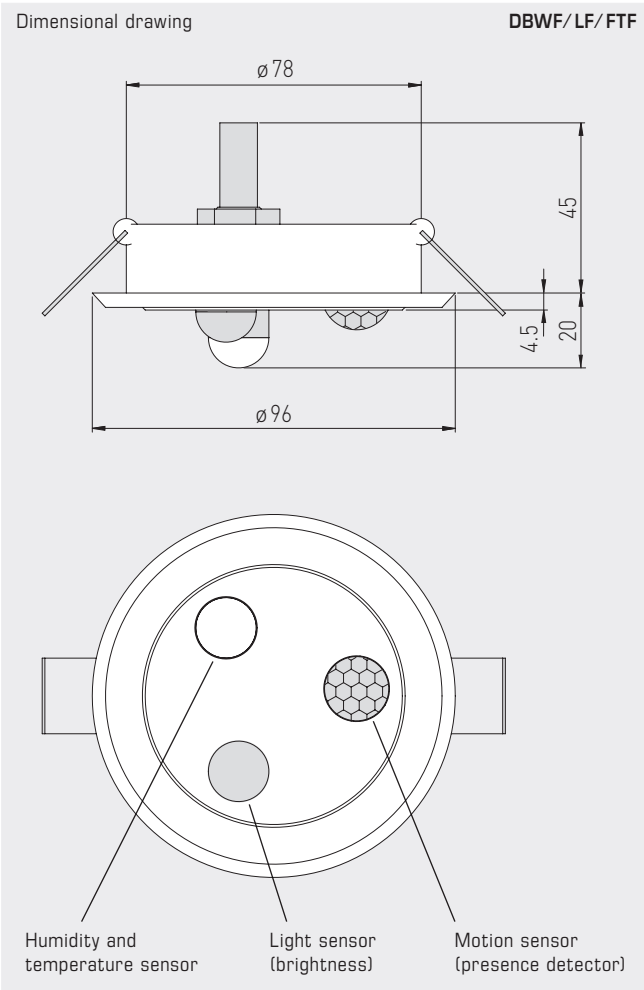

KINASGARD® DBWF/LF/FTF In-ceiling motion, light, temperature and humidity sensor

Type / WG02	Detection, Measuring Range	Output	Item No.
DBWF-LF-FTF-W			
1. Presence + Motion	yes / no (relay on / off)	Changeover contact	1401-6114-3100-000
2. Light Intensity	0...1000 lux / 0...5000 lux (DIP)	0-10V (linearised)	
3. Temperature	0 ... 50 °C	0- 10V	
4. Humidity	0...100% RH	0- 10V	

Outputs: **0-10V or inverted 10-0V** (selectable via DIP switches)

