

Condensation-protected on-wall humidity and temperature sensor for "high humidity", relative/absolute humidity, mixture ratio, dew point, wet bulb temperature and temperature, calibratable, with multi-range switching, with active and switching output

Condensation-protected on-wall sensor **HYGRASREG® AFTF-35** with active and switching output, housing made of impact-resistant plastic with quick-locking screws, cable gland, plastic sinter filter (replaceable), optionally with/without display, for detecting relative humidity (0...100 % RH) and temperature (4 switchable measuring ranges, max. 0...+100 °C) as well as for determining various parameters of humidity measurement technology. The measuring transducer converts the measured variables into a standard signal of 0-10V or 4...20 mA.

The unit is specially designed for use in the **high humidity range** (95...99 % RH). A long-term stable, **digital humidity and temperature sensor** is used. Overtemperature prevents or hinders dew formation on the humidity sensor. A second, separate temperature measuring element is used to determine the actual relative humidity of the ambient air. The following measured variables are calculated internally from these parameters and are retrievable via output **OUT3**: absolute humidity, mixing ratio, dew point and wet bulb temperature (can be changed via DIP switch).

The sensor is used in medical technology, refrigeration technology, control technology, air conditioning and clean room technology. The sensor is factory-calibrated; an environmental precision adjustment by an expert is possible.

TECHNICAL DATA

Power supply:	24 V AC/DC (± 10 %)
Working resistance:	> 100 kOhm for U variant; 100...500 Ohm for I variant
Power consumption:	typically < 6 W at 24 V DC, peak current 200 mA
Measured variables:	relative humidity [% RH], temperature [°C]
Parameters:	absolute humidity [g/m ³], mixture ratio [g/kg], dew point [°C], wet bulb temperature [°C]
Outputs:	3 active outputs (0-10V or 4...20 mA) 1 changeover contact
Sensor:	digital humidity sensor with integrated temperature sensor , low hysteresis, high long-term stability, with condensation protection through heating function (plus a second, separate temperature measuring element)
Sensor protection:	plastic sinter filter, Ø 16 mm, L = 35 mm, exchangeable (optional metal sinter filter, Ø 16 mm, L = 32 mm)

HUMIDITY

Measuring range, humidity:	0...100 % RH
Accuracy in humidity:	typically ± 3.0 % (30...70 % RH) at +25 °C, otherwise ± 3.5 % (deviations of alternative parameters result from deviations from humidity and temperature.)
Output humidity:	0-10V for U variant; 4...20 mA for I variant

TEMPERATURE

Temperature measuring range:	Multi-range switching with 4 switchable measuring ranges (see table) 0...+50 °C (default); -20...+50 °C; -20...+80 °C; 0...+100 °C
Accuracy in temperature:	typically ± 0.5 K at +25 °C
Temperature output:	0-10V for U variant; 4...20 mA for I variant
Long-term stability:	± 1 % per year
Response time (t90):	< 60 s
Warm-up time:	< 10 min
Electrical connection:	0.14 - 1.5 mm ² , via terminal screws
Cable connection:	Cable gland , plastic (M 16 x 1.5; with strain relief, exchangeable, max. inner diameter 10.4 mm)
Housing:	Plastic, UV-resistant, material polyamide, 30 % glass-globe reinforced, with quick-locking screws (slotted/Phillips head combination), colour traffic white (similar to RAL 9016), housing cover for display is transparent!
Housing dimensions:	126 x 90 x 50 mm (Tyr 2)
Protective tube:	made of stainless steel V2A (1.4301), Ø 16 mm, NL = 55 mm (combined humidity and temperature measuring element) and of stainless steel V4A (1.4571), Ø 6 mm, NL = 65 mm (second, separate temperature measuring element)
Process connection:	via screws
Ambient temperature:	storage -20...+50 °C; operation -20...+50 °C
Permitted humidity:	< 99 % RH, non-precipitating air free of harmful substances
Protection class:	III (according to EN 60 730)
Protection type:	IP 65 (according to EN 60 529) housing, IP20 sensor technology
Standards:	CE-conformity according to EMC Directive 2014/30/EU
Optional:	Display with illumination , three-line, cutout approx. 70 x 40 mm (W x H), to display the ACTUAL humidity and ACTUAL temperature and/or selectable parameters

FUNCTION

A constant overtemperature of the humidity sensor makes its dewing considerably more difficult or prevents its formation within the limits of the system. A faster reaction speed is achieved in the case of humidity fluctuations, even in the range above 95 % RH. The sensor (combined humidity and temperature measuring element) is heated approx. 3 K above the ambient temperature. The actual relative humidity is determined from the measured relative humidity at overtemperature, the chip temperature of the sensor and the ambient temperature (via a second, separate temperature measuring element).



NEW

S+S REGELTECHNIK

HYGRASREG® **AFTF-35**

Condensation-protected on-wall humidity and temperature sensor for "high humidity", relative/absolute humidity, mixture ratio, dew point, wet bulb temperature and temperature, calibratable, with multi-range switching, with active and switching output

Dimensional drawing [mm]

AFTF-35

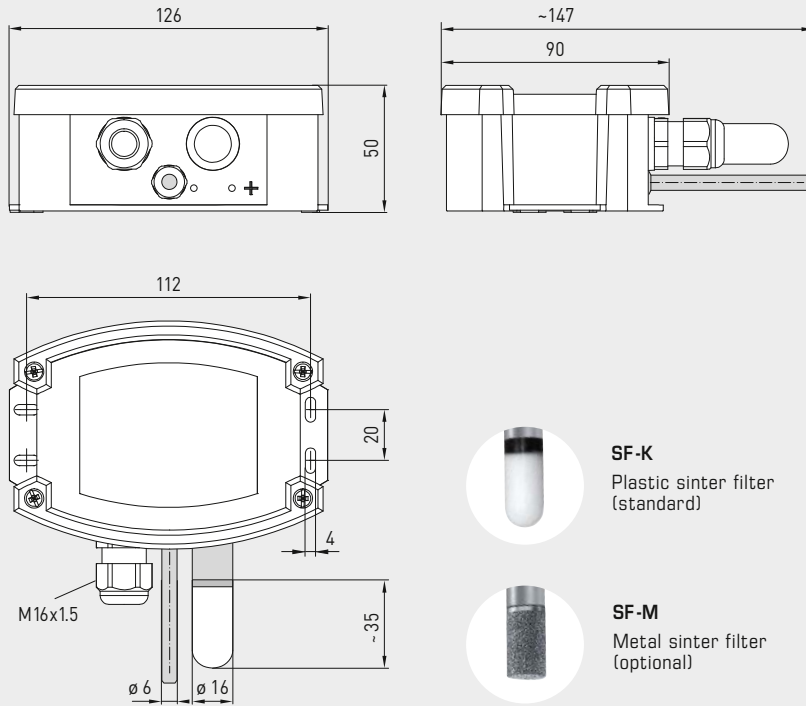

SF-K
Plastic sinter filter (standard)



SF-M
Metal sinter filter (optional)

AFTF-35
with plastic sinter filter (standard)



AFTF-45
with display



Temperature table
MR: -20...+80 °C

°C	U _A [V]	I _A [mA]
-20	0.0	4.0
-15	0.5	4.8
-10	1.0	5.6
-5	1.5	6.4
0	2.0	7.2
5	2.5	8.0
10	3.0	8.8
15	3.5	9.6
20	4.0	10.4
25	4.5	11.2
30	5.0	12.0
35	5.5	12.8
40	6.0	13.6
45	6.5	14.4
50	7.0	15.2
55	7.5	16.0
60	8.0	16.8
65	8.5	17.6
70	9.0	18.4
75	9.5	19.2
80	10.0	20.0

Temperature table
MR: -20...+50 °C

°C	U _A [V]	I _A [mA]
-20	0.0	4.0
-15	0.7	5.1
-10	1.4	6.3
-5	2.1	7.4
0	2.9	8.6
5	3.6	9.7
10	4.3	10.9
15	5.0	12.0
20	5.7	13.1
25	6.4	14.3
30	7.1	15.4
35	7.9	16.6
40	8.6	17.7
45	9.3	18.9
50	10.0	20.0

Temperature table
MR: 0...+50 °C

°C	U _A [V]	I _A [mA]
0	0.0	4.0
5	1.0	5.6
10	2.0	7.2
15	3.0	8.8
20	4.0	10.4
25	5.0	12.0
30	6.0	13.6
35	7.0	15.2
40	8.0	16.8
45	9.0	18.4
50	10.0	20.0

Temperature table
MR: 0...+100 °C

°C	U _A [V]	I _A [mA]
0	0.0	4.0
5	0.5	4.8
10	1.0	5.6
15	1.5	6.4
20	2.0	7.2
25	2.5	8.0
30	3.0	8.8
35	3.5	9.6
40	4.0	10.4
45	4.5	11.2
50	5.0	12.0
55	5.5	12.8
60	6.0	13.6
65	6.5	14.4
70	7.0	15.2
75	7.5	16.0
80	8.0	16.8
85	8.5	17.6
90	9.0	18.4
95	9.5	19.2
100	10.0	20.0

Humidity table
MR: 0...100 % RH

% RH	U _A [V]	I _A [mA]
0	0.0	4.0
5	0.5	4.8
10	1.0	5.6
15	1.5	6.4
20	2.0	7.2
25	2.5	8.0
30	3.0	8.8
35	3.5	9.6
40	4.0	10.4
45	4.5	11.2
50	5.0	12.0
55	5.5	12.8
60	6.0	13.6
65	6.5	14.4
70	7.0	15.2
75	7.5	16.0
80	8.0	16.8
85	8.5	17.6
90	9.0	18.4
95	9.5	19.2
100	10.0	20.0

Condensation-protected on-wall humidity and temperature sensor for "high humidity", relative/absolute humidity, mixture ratio, dew point, wet bulb temperature and temperature, calibratable, with multi-range switching, with active and switching output

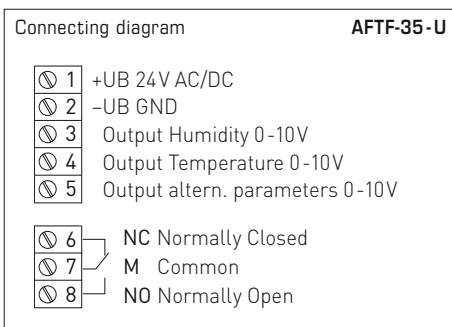
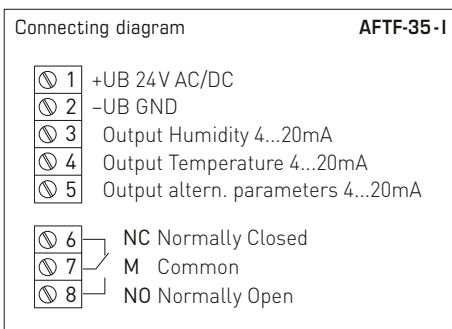
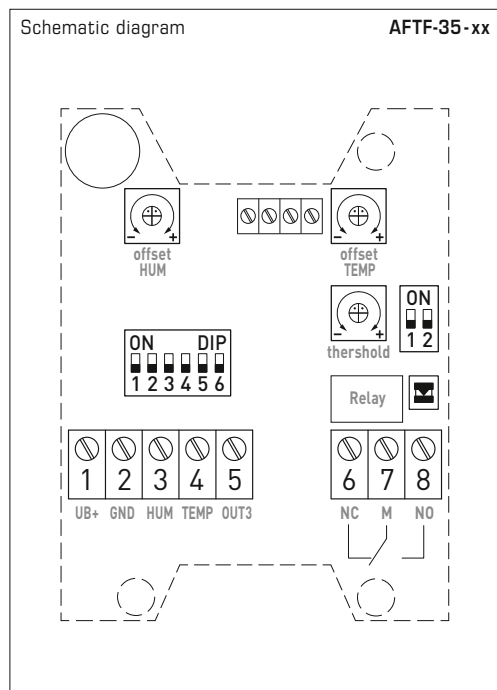

Measuring ranges temperature	DIP 1	DIP 2
0...+50 °C (default)	OFF	OFF
-20...+50 °C	ON	OFF
-20...+80 °C	OFF	ON
0...+100 °C	ON	ON



Relay function assignment	DIP 1	DIP 2
inactive (default)	OFF	OFF
Humidity	ON	OFF
Temperature	OFF	ON
alternative parameters	ON	ON

Measuring ranges alternative parameters	DIP 3	DIP 4	DIP 5
(A) 0...20 g/m ³ (default)	OFF	OFF	OFF
(A) 0...25 g/m ³	ON	OFF	OFF
(R) 0...20 g/kg	OFF	ON	OFF
(R) 0...25 g/kg	ON	ON	OFF
(D) 0...+50 °C	OFF	OFF	ON
(D) -20...+50 °C	ON	OFF	ON
(W) -30...+30 °C	OFF	ON	ON
(W) -20...+50 °C	ON	ON	ON

(A) = absolute humidity [g/m³]
 (R) = mixture ratio [g/kg]
 (D) = dew point [°C]
 (W) = wet bulb temperature [°C]

Note: For factory service only, it must be set to "OFF" during operation!	DIP 6
Operation (default)	OFF

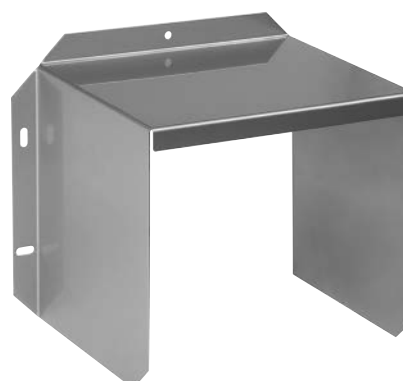

WS-03
Weather and sun protection hood



S+S REGELTECHNIK

NEW

HYGRASREG® **AFTF-35**

Condensation-protected on-wall humidity and temperature sensor for "high humidity", relative/absolute humidity, mixture ratio, dew point, wet bulb temperature and temperature, calibratable, with multi-range switching, with active and switching output



HYGRASREG® AFTF-35 Condensation-protected on-wallsensor for high humidity

Type/ WG02	Measuring Range Humidity	Temperature	Output active	Output switching	Display	Item No.
AFTF-35-I						I variant
AFTF-35-I/W	0...100%RH 0...20 g/m ³ (A) 0...25 g/m ³ (A) 0...20 g/kg (R) 0...25 g/kg (R) 0...+50 °C (D) -20...+50 °C (D) -30...+30 °C (W) -20...+50 °C (W)	0...+50 °C -20...+50 °C -20...+80 °C 0...+100 °C	3x 4...20 mA	1x Changeover contact		1201-714B-1000-000
AFTF-35-I/W LCD	(as above)	(as above)	3x 4...20 mA	1x Changeover contact	■	1201-714B-1200-000
AFTF-35-U						U variant
AFTF-35-U/W	(as above)	(as above)	3x 0-10 V	1x Changeover contact		1201-714A-1000-000
AFTF-35-U/W LCD	(as above)	(as above)	3x 0-10 V	1x Changeover contact	■	1201-714A-1200-000

Note **Alternative parameters** are calculated internally from the measured variables, which are retrievable via the active output **OUT3**: absolute humidity, mixing ratio, dew point and wet bulb temperature (can be changed via DIP switch)

ACCESSORIES		
SF-M	Metal sinter filter, Ø 16 mm, L = 32 mm, exchangeable stainless steel V4A (1.4404)	7000-0050-2200-100
WS-03	Weather and sun protection hood , 200 x 180 x 150 mm, stainless steel V2A (1.4301)	7100-0040-6000-000

for further information see see chapter Accessories!

